

Setting up

Remove the CDL Data Logger from the packing. Although new batteries are installed in the device prior to delivery, it is recommended that the batteries are checked before installation.

Programming

Before installation, connect the logger to a personal computer (PC) with the CDL/PC connection cable. Programming is done with the CDL Win-Software and details of the programming are described in the CDL Win-Software instruction manual. Unused menus will be barred.

Installation

At site, connect the pulsers and sensors to the corresponding pre-programmed ports. Recording starts at the pre-programmed time.

Caution: Unused ports must be tightly sealed using the screw caps to avoid any water leakage.

Hint: After installation, the incoming instantaneous values can be displayed at the LC-display. The system can be tested in this manner. This is also possible before the programmed measuring period commences.

Display

The values can be read from the built in LC-display during and after logging.

To offer maximum water resistance, the function keys are magnet sensitive sensors which can be activated by the magnetic pin.

The display is activated by covering the (*ENTER*) key. Horizontal navigation through the display menu is achieved with the (-) and (+) keys and vertical navigation is achieved with the (*ENTER*) key. For more details, please refer to the schematic diagram of the LC-display in this leaflet.

Down-loading

The values can be down-loaded at any time during or after the measurement period. This is done either by cable connection directly to a PC, modem, or by radio transmission. With the use of the CDL Win-software installed on a PC, down-loading and assessment is easy and straight-forward.

Battery check

New batteries should have a voltage of $6 \times 1.5 = 9$ Volt. If the battery voltage falls below 6.3 Volt, a warning will be displayed on the LC-display. Further menus will be barred and analogue measurement is automatically stopped. Nevertheless, the saved data will not be lost for up to 3 months after the first battery warning and can be down-loaded even if the LC-display is not readable.

Changing batteries

The batteries should be changed if the voltage falls below 7.5 Volt. To do this, loosen the 4 screws securing the battery compartment cover, lift the cover and remove the battery pack carefully. Care must be taken to avoid disconnecting the power cable.

Caution: When changing the batteries the LC-display must not be activated.

Always change all 6 batteries using type LR6 (Mignon). Standard alkaline batteries should be used. Remove and replace only a single battery at a time.

Note: If the Data Logger is without power for longer than 30 seconds, all data and programming will then be lost.

Battery test

After checking that the unit functions, the battery compartment must be closed carefully. Make sure that the cable and gasket are not pinched under the cover when replacing the cover.

If a sequence of tests is displayed after changing the batteries, the batteries were so flat that a restart was executed. All saved data and programming will then be lost.

The Logger must be re-programmed before being used again. If nothing is displayed after changing the batteries, all data and programming are still stored in the memory. Finally the LC-display should be activated to check the battery voltage and, in case of interruption, to restart the logging automatically.

Instructions

CDL DATA-LOGGER

CDL - 1U, CDL - 2U, CDL - 4U

Data logger for water supply management

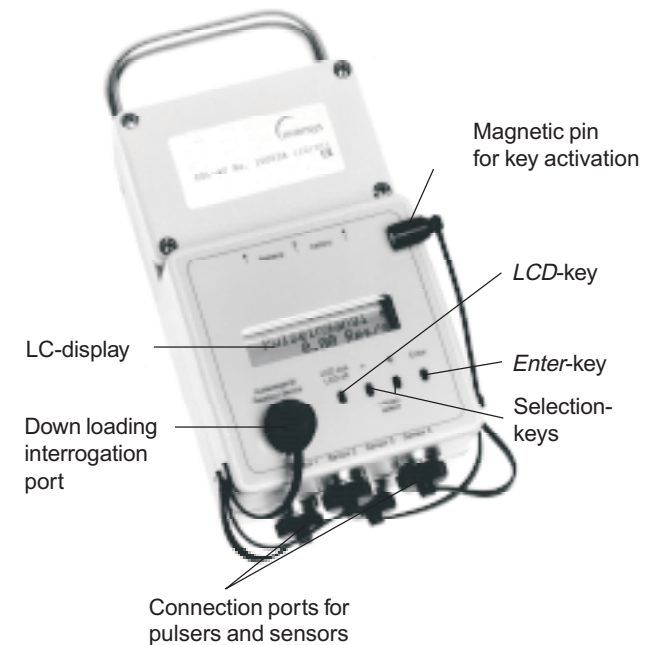

The CDL DATA-Logger is a portable, robust and water resistant data recorder. The data are recorded without mains power connection.

Accessories for various applications are available, they include; Pulsers, Pressure sensors, CDL/PC connection cable and CDL Win - Software.



Sensus Metering Systems GmbH
Hannover
Meineckestr. 10 · D-30880 Laatzen
Phone +49 (0)5102 / 74-0
Fax +49 (0)5102 / 74-148

Schematic diagram of the display menu

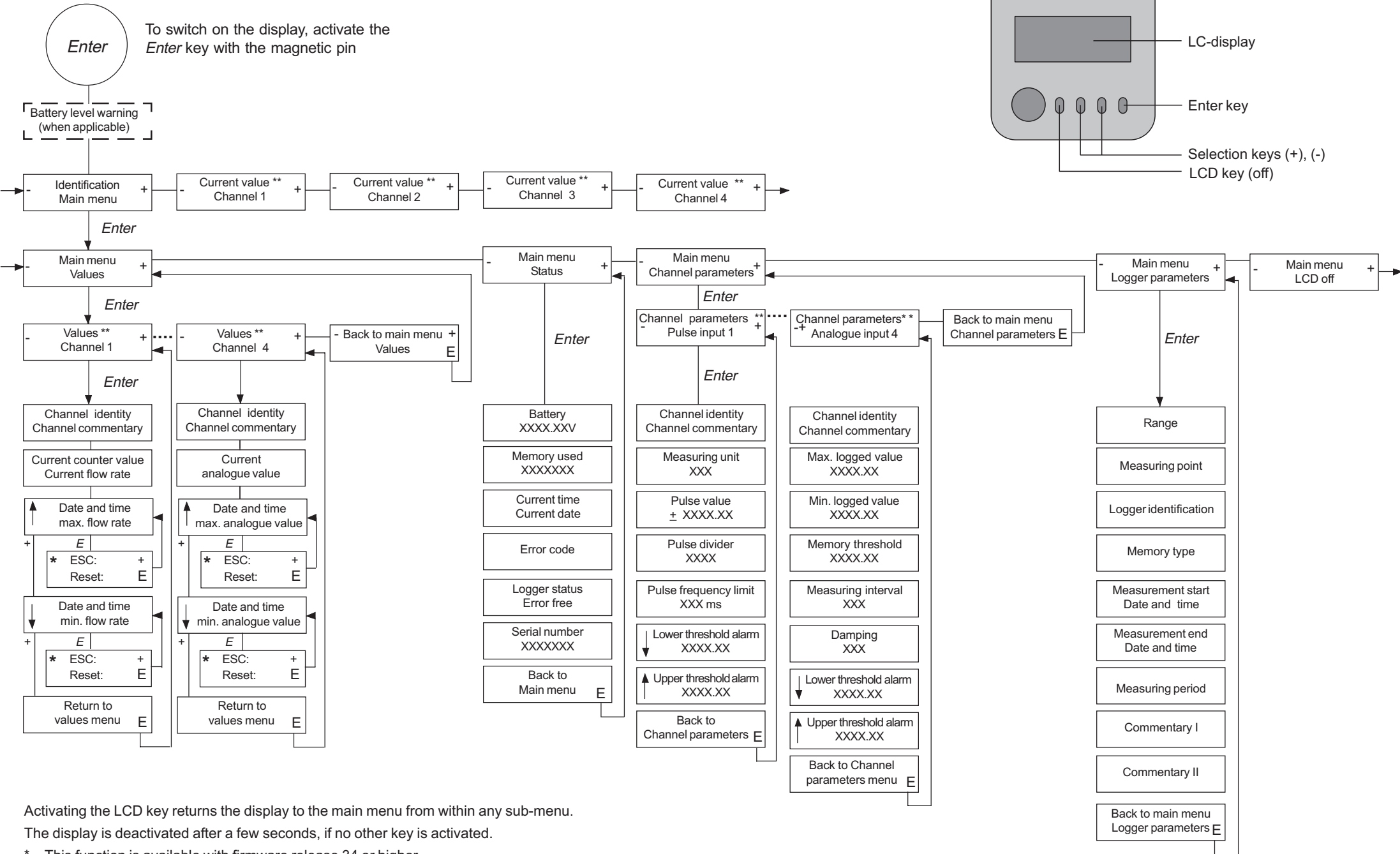
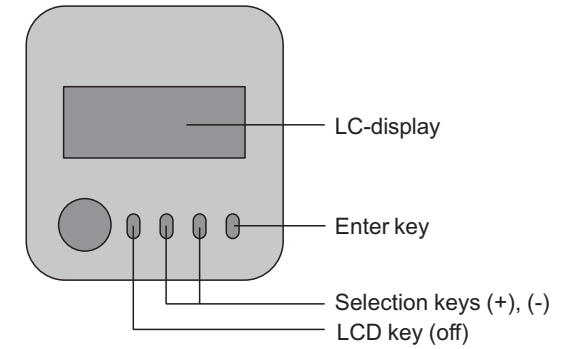

Activating the LCD key returns the display to the main menu from within any sub-menu.

The display is deactivated after a few seconds, if no other key is activated.

* This function is available with firmware release 34 or higher.

** Reading depends on if and how the channel is programmed and the number of channels.